

Laundry
Scale: 3/8"

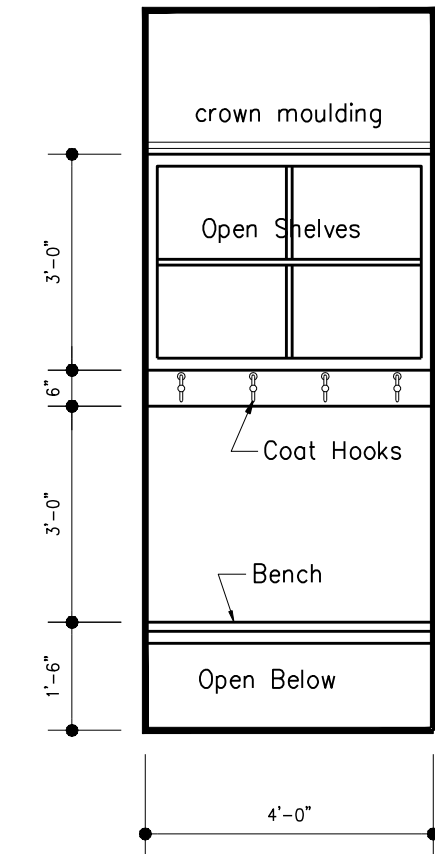

Mud Room
Scale: 3/8"

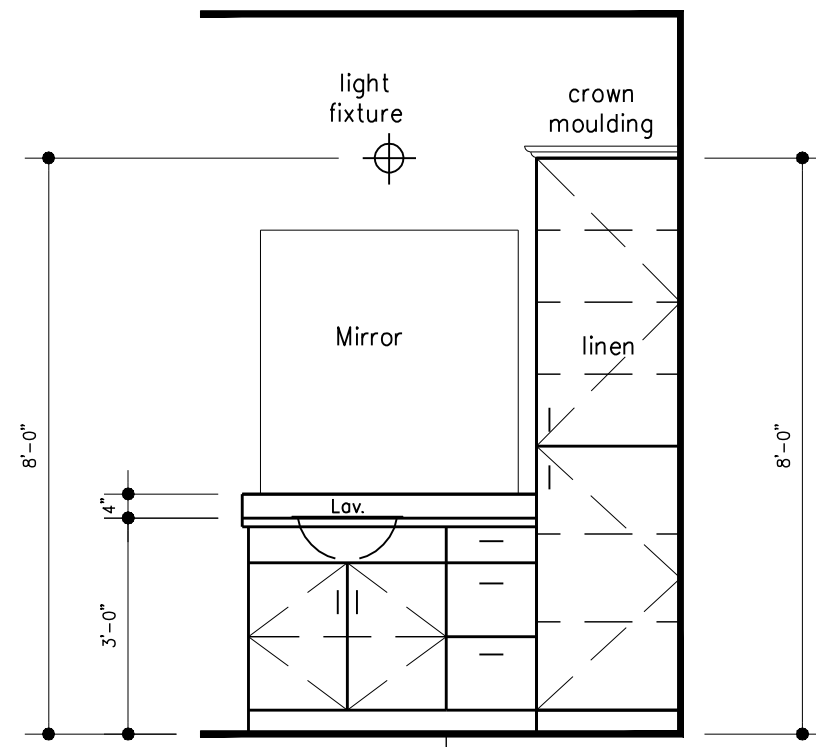

Master Bath
Scale: 3/8"

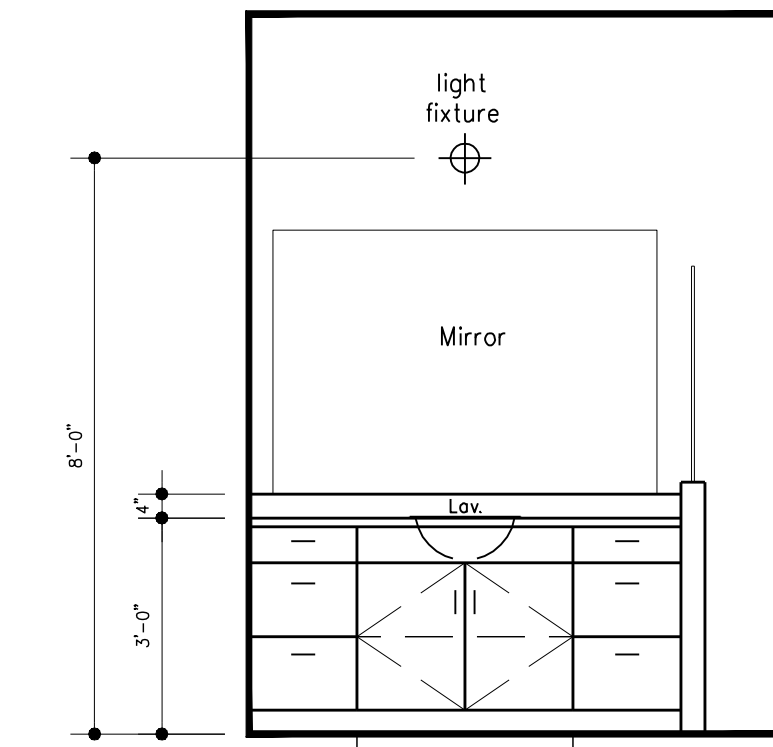

Master Bath
Scale: 3/8"

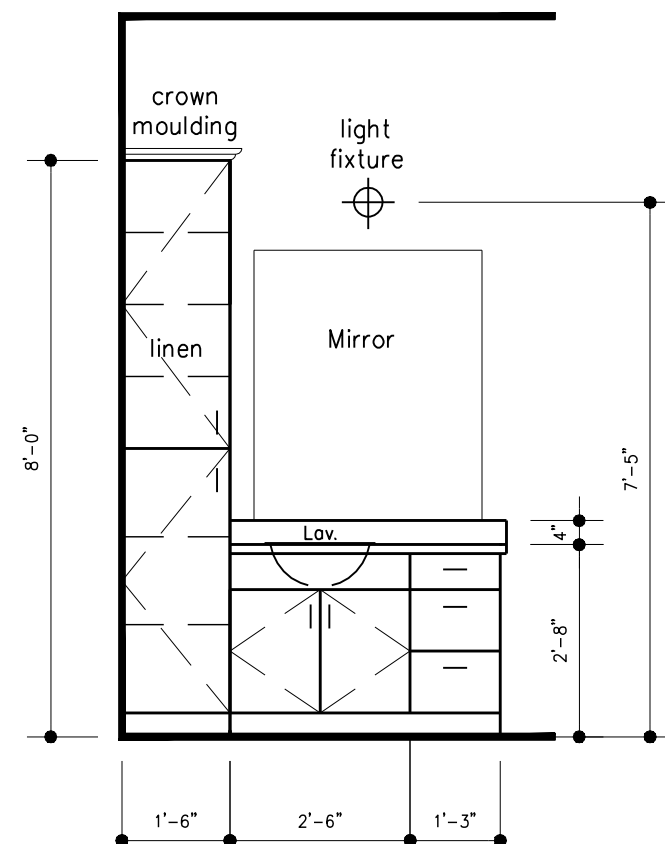

Bath #2
Scale: 3/8"

WORKING DRAWINGS SHALL NOT BE SCALED. CONTRACTOR AND /OR SUB-CONTRACTOR SHALL REVIEW AND VERIFY ALL NOTES AND MEASUREMENTS BEFORE PROCEEDING WITH ANY WORK OR ORDERING MATERIALS. VERIFY FOR CLARITY AND CONSULT CONTRACTOR OR FIELD MANAGER FOR ANY DISCREPANCIES IN OR OMISSIONS FROM THE WORKING DRAWINGS. GENERAL CONTRACTOR AND SUB-CONTRACTORS ARE RESPONSIBLE TO INSURE CONSTRUCTION OF PROJECT MEETS ALL LOCAL AND APPLICABLE CODES. THESE DRAWINGS ARE OF BUILDERS TYPE AND THE DESIGNER/DRAFTER OF THIS SET OF PLANS, HEREBY NOTIFIES BOTH OWNER AND CONTRACTOR RELEASE OF LIABILITIES TO PROBLEMS AT THE JOB SITE IN REFERENCE TO SAID WORKING DRAWINGS.

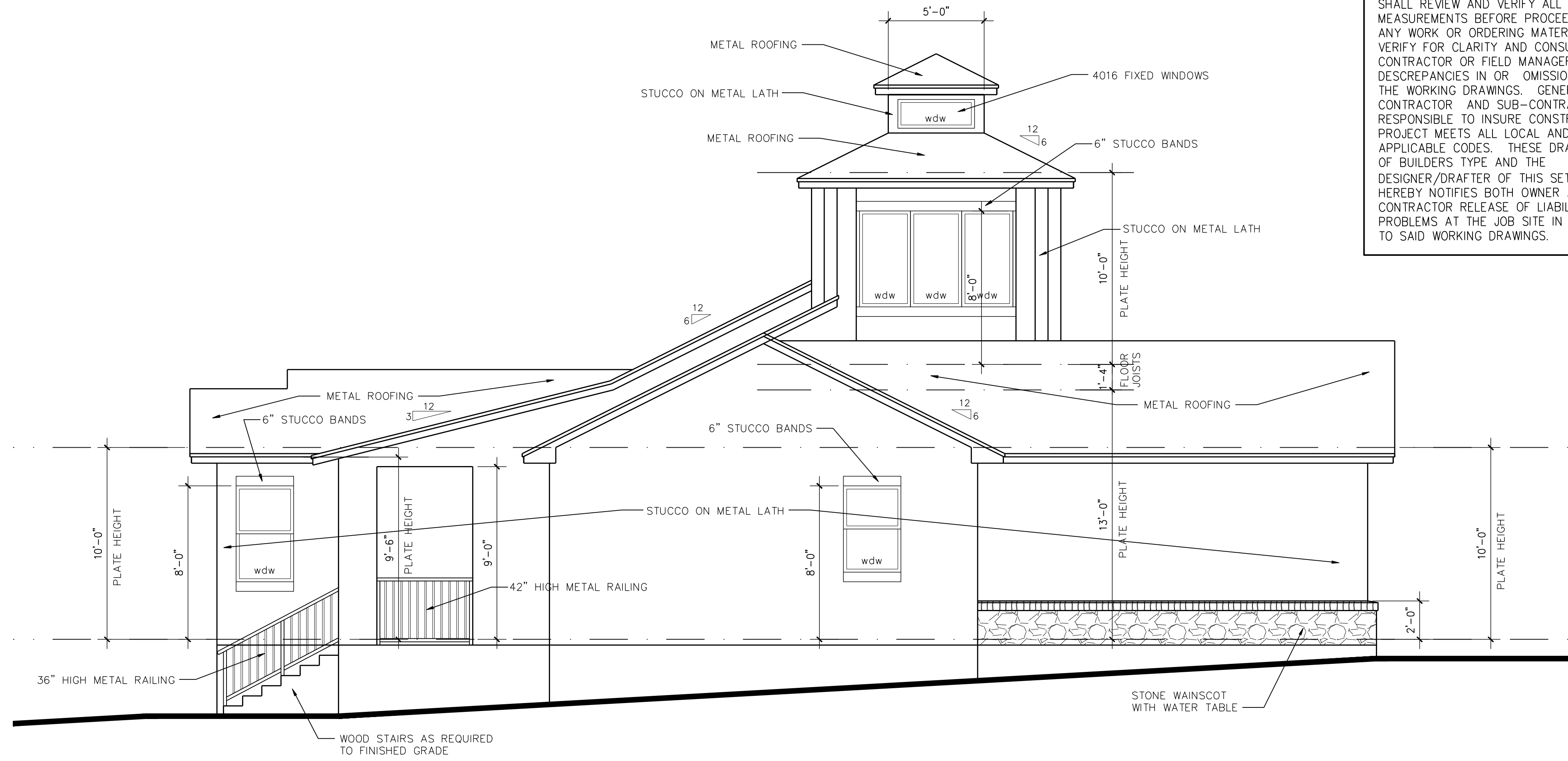

LEFT SIDE ELEVATION

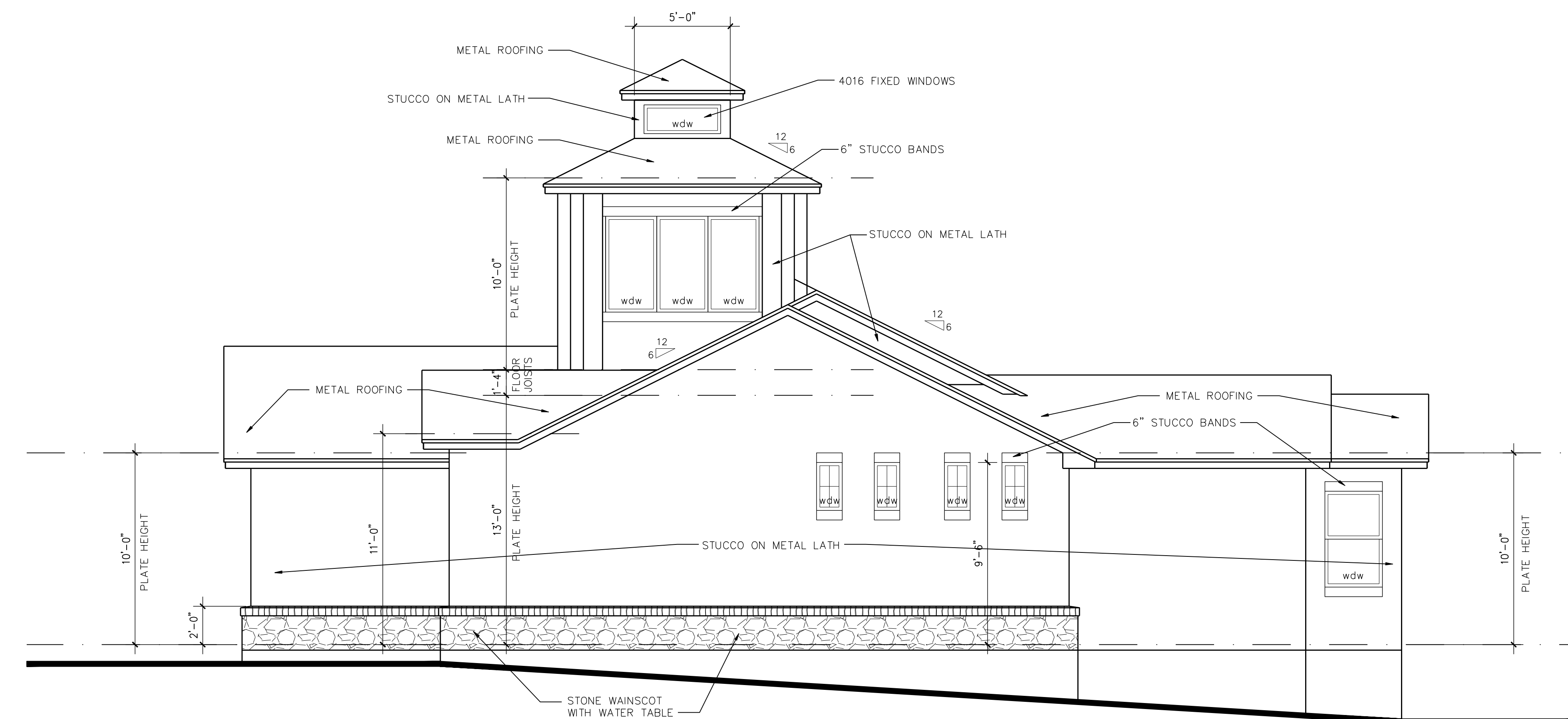

RIGHT SIDE ELEVATION

SCALE: 1/4" = 1'-0"

Lot 20038 Prospect

LLANO COUNTY, TEXAS

**MICHAEL CORTEZ
DESIGN GROUP
(210) 860-6920**

EVERVIEW HOMES PLAN 1998

DATE: 01-16-2020

SHEET

A-4